

---

# RingCore200

## *Optimized Vibration Driver*

---

*CORERIVER Semiconductor reserves the right to make corrections, modifications, enhancements, improvements, and other changes to its products and services at any time.*

- ◆ *To discontinue any product or service, CORERIVER should inform customers of that before 3 months through its homepage.*
- ◆ *Customers should obtain the latest relevant information before placing orders and should verify that such information is current and complete.*
- ◆ *The CORERIVER Semiconductor products listed in this document are intended for usage in general electronics applications. These CORERIVER Semiconductor products are neither intended nor warranted for usage in equipment that requires extraordinarily high quality and/or reliability or a malfunction or failure of which may cause loss of human life or bodily injury.*

**Copyright CORERIVER Semiconductor Co., Ltd. 2012**  
**All Rights Reserved**

# 1 RingCore200 Overview

## 1.1 General Description

**RingCore200** is a linear motor driver IC to drive Linear Resonant Actuator (LRA) and Eccentric Rotating Mass (ERM). It generates a pulse width modulation (PWM) signal for driving a linear motor. It can adjust the frequency of the PWM signal to maximize the vibration amplitude of the linear motor.

**RingCore200** operates over the temperature range of  $-40^{\circ}\text{C}$  to  $+85^{\circ}\text{C}$ , and is assembled in 8-pin DFN package.

## 1.2 Features

- ◆ Motor Driving Frequency Tuning (Maximum Vibration Frequency Search)
- ◆ Supports two actuator types (ERM / LRA)
- ◆ Drives low-impedance actuator.
  - The minimum limit:  $7.5\Omega$
- ◆ Wide resonant output frequency:  $80 \sim 390$  Hz
- ◆ Almost Rail-to-Rail vibration (Output swing from  $V_{SS} + 100\text{mV}$  to  $V_{DD} + 100\text{mV}$ )
- ◆ Over-current limitation
- ◆ Fast wake-up time (Output available 1ms after EN)
- ◆ Single-PWM input for all actuator types (10 kHz ~ 50 kHz)
- ◆ Built-in weak pull down on all inputs
- ◆ Standby Current: Max. 1uA
- ◆ Settable filter in GAIN using an external capacitor
- ◆ DC gain settable in GAIN using an external resistor
- ◆ Typical 50mV offset on output (Maximum 200mV)
- ◆ 2.0mm X 2.0mm DFN package

### 1.3 Applications

- ◆ Mobile Phones & Smart Phones
- ◆ Portable MP3, MP4
- ◆ Navigation Systems
- ◆ Joysticks

### 1.4 Product Family Guide

Product	Output Resonant Frequency [Hz]	PWM input Resonant Frequency [KHz]	Package	Auto Tuning
<b>RingCore200-DF8IP</b>	<b>80 ~ 390</b>	<b>10 ~ 50</b>	<b>2 x 2 mm 8-pin DFN</b>	-
RingCore210-DF10IP	80 ~ 390	10 ~ 50	2 x 2 mm 10-pin DFN	Support

## 2 Pin Configuration

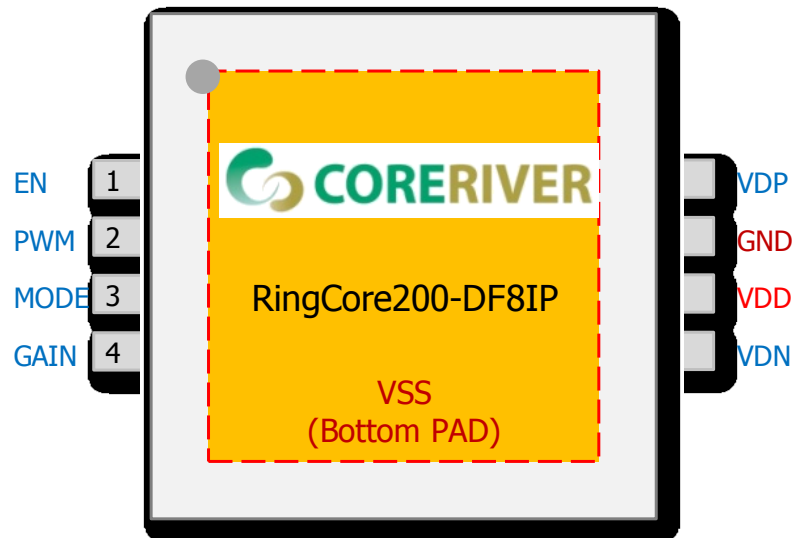

8-pin DFN Package Diagram

### 3 Pin Description

Pin No.	Name	Type	Description	Share Pins
1	EN	I	Turns the circuit on.	
2	PWM	I	PWM input sets desired vibration magnitude (1% to 99%) with pull-down. - 1% : Full braking - 50% : No vibration - 99% : Full vibration	
3	MODE	I	High: LRA mode. Low: ERM mode.	
4	GAIN	I	Resistor to VDN sets DC Gain. Capacitor to VDN sets Output Filter Frequency.	
5	VDN	O	Negative Actuator Connector.	
6	VDD	PWR	Power supply	
7	GND	GND	Power ground	
8	VDP	O	Positive actuator connector	

## 4 Typical Application

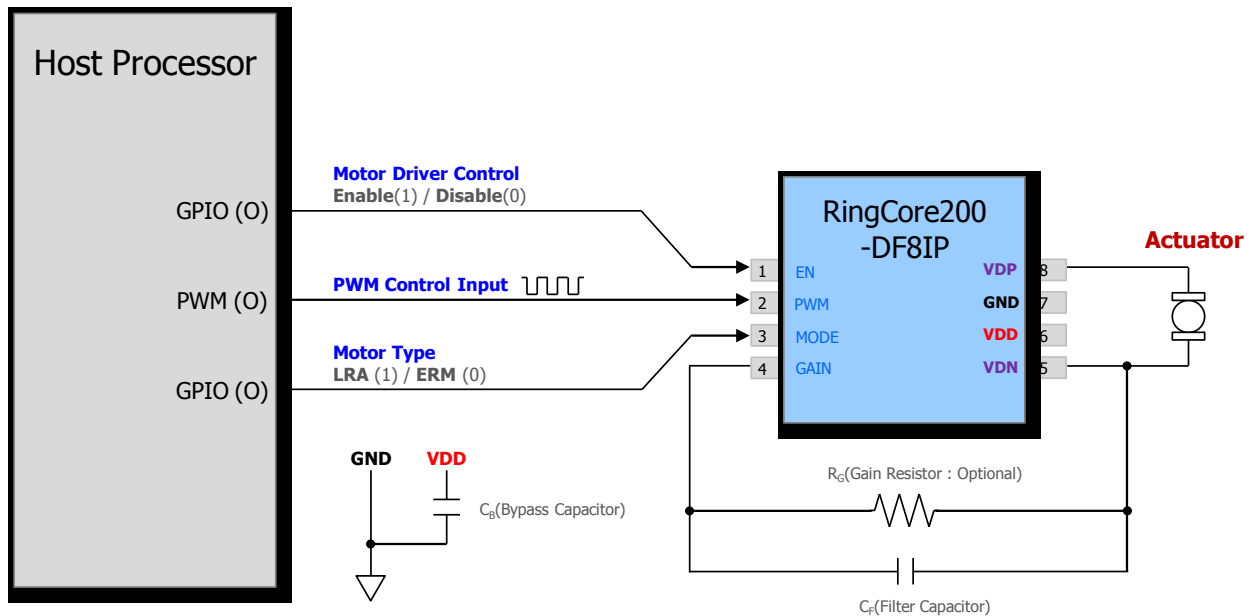

- ◆  $V_{DD}$  power should be supplied by regulated power
- ◆ EN pin of RingCore200 should be controlled by GPIO of main CPU to disable RingCore200
- ◆ The  $R_G$ (Gain Resistor) is used to set the output(VDP, VDN) voltage gain.
  - ✓ The output gain by the  $R_G$  optionally. (default output gain is '1' without  $R_G$ )
  - ✓ If  $R_G$  is  $60\text{ k}\Omega$ , output gain is half of default value (0.5).
  - ✓ If  $V_{DD}$  is higher than required, adjusting the value of  $R_G$  to reduce output voltage.
  - ✓ The value of  $R_G$  is based on  $V_{DD}$  and motor's operating ratings.
  - ✓ Output voltage only can be reduced by  $R_G$ .
- ◆ The  $C_F$ (Filter Capacitor) is used to regulate output high frequency harmonics.
  - ✓ Increasing the value of  $C_F \rightarrow$  Removing high frequency harmonics of the PWM on the outputs.
- ◆ In LRA mode, PWM frequency is same to 128 times of the LRA's resonant frequency.
- ◆ Don't need any protection component on VDP, VDN

## 5 Reference Table for $R_G$

◆ How to use reference table

- ✓ Define input  $V_{DD}$  voltage and Search actuator's operating ratings ( $V_{rms}$ )
- ✓ Tracking down output voltage(VDP, VDN) as you want to use
- ✓ Find the  $R_G$  on left side
- ✓ For example :  $V_{DD}$  is 3.7V, LRA's operating ratings (Input  $V_{rms}$ ) is  $2.0V_{rms}$  →  $R_G$  value is 91 k $\Omega$

Note : This table's  $R_G$  value is estimated value, so should adjust by developer's experiment.

If  $V_{DD}$  don't exceed actuator's ratings,  $R_G$  can be removed.

$R_G \backslash V_{DD}$	2.0V	2.1V	2.2V	2.3V	2.4V	2.5V	2.6V	2.7V	2.8V
68K	0.930	0.980	1.028	1.076	1.123	1.170	1.219	1.265	1.311
75K	0.974	1.025	1.074	1.123	1.173	1.223	1.271	1.318	1.364
82K	1.016	1.067	1.118	1.169	1.222	1.271	1.320	1.369	1.419
91K	1.065	1.117	1.172	1.227	1.278	1.330	1.380	1.434	1.486
100K	1.096	1.150	1.206	1.260	1.312	1.364	1.419	1.473	1.526
110K	1.135	1.192	1.249	1.303	1.357	1.413	1.469	1.523	1.580
120K	1.165	1.223	1.279	1.335	1.391	1.449	1.505	1.563	1.623
130K	1.199	1.257	1.314	1.371	1.431	1.489	1.548	1.608	1.671
150K	1.247	1.305	1.364	1.426	1.487	1.548	1.611	1.676	1.740
160K	1.269	1.329	1.389	1.452	1.514	1.577	1.643	1.709	1.773
180K	1.312	1.373	1.438	1.501	1.567	1.635	1.703	1.770	1.837
200K	1.336	1.400	1.466	1.531	1.599	1.669	1.737	1.805	1.875
220K	1.365	1.431	1.497	1.565	1.636	1.707	1.776	1.847	1.919
240K	1.388	1.456	1.523	1.593	1.666	1.737	1.808	1.881	1.955
270K	1.421	1.487	1.558	1.632	1.705	1.778	1.851	1.927	2.002
300K	1.443	1.511	1.584	1.659	1.733	1.807	1.883	1.960	2.036
330K	1.454	1.524	1.597	1.673	1.747	1.822	1.899	1.977	2.054
360K	1.480	1.552	1.629	1.705	1.780	1.858	1.937	2.015	2.095
390K	1.503	1.576	1.655	1.732	1.808	1.889	1.968	2.049	2.129
430K	1.513	1.588	1.667	1.745	1.822	1.903	1.984	2.065	2.145
470K	1.529	1.606	1.686	1.763	1.843	1.925	2.006	2.089	2.168
510K	1.543	1.621	1.701	1.779	1.860	1.942	2.024	2.107	2.186

$R_G \backslash V_{DD}$	2.9V	3.0V	3.1V	3.2V	3.3V	3.4V	3.5V	3.6V	3.7V
68K	1.355	1.401	1.448	1.493	1.539	1.586	1.634	1.682	1.730
75K	1.412	1.461	1.509	1.556	1.605	1.656	1.707	1.757	1.806
82K	1.470	1.518	1.569	1.621	1.674	1.727	1.778	1.830	1.883
91K	1.537	1.591	1.646	1.701	1.756	1.810	1.864	1.921	1.977
100K	1.580	1.637	1.694	1.751	1.806	1.863	1.920	1.977	2.034
110K	1.639	1.698	1.756	1.814	1.872	1.930	1.988	2.046	2.104
120K	1.683	1.744	1.802	1.862	1.924	1.982	2.040	2.098	2.156
130K	1.732	1.793	1.855	1.918	1.982	2.045	2.108	2.171	2.234
150K	1.803	1.868	1.934	2.000	2.066	2.132	2.198	2.264	2.330
160K	1.838	1.905	1.973	2.039	2.107	2.174	2.237	2.298	2.359
180K	1.906	1.976	2.045	2.116	2.184	2.249	2.313	2.377	2.441
200K	1.947	2.017	2.089	2.159	2.227	2.291	2.357	2.422	2.487
220K	1.992	2.065	2.138	2.208	2.274	2.340	2.408	2.474	2.540
240K	2.028	2.103	2.175	2.244	2.312	2.380	2.448	2.516	2.584
270K	2.078	2.153	2.225	2.294	2.363	2.432	2.502	2.573	2.644
300K	2.114	2.189	2.259	2.330	2.401	2.471	2.543	2.615	2.687
330K	2.132	2.206	2.277	2.348	2.420	2.490	2.563	2.637	2.711
360K	2.172	2.245	2.318	2.390	2.462	2.536	2.611	2.686	2.761
390K	2.206	2.279	2.353	2.427	2.500	2.576	2.652	2.730	2.808
430K	2.221	2.295	2.370	2.444	2.519	2.595	2.672	2.751	2.830
470K	2.244	2.319	2.394	2.489	2.545	2.623	2.702	2.783	2.864
510K	2.262	2.338	2.414	2.489	2.567	2.645	2.725	2.807	2.889



## 6 Absolute Maximum Ratings

Item	Conditions	Range
Voltage on any pin relative to Ground	-	-0.5 V to ( $V_{DDIO}+0.5V$ )
Voltage in $V_{DD}$ relative to Ground	-	-0.5V to 3.7V
Output Voltage	-	-0.5 V to ( $V_{DD}+0.5V$ )
Output Current High	One I/O pin active	-25mA
	All I/O pin active	-100mA
Output Current Low	One I/O pin active	+30mA
	All I/O pin active	+150mA
Storage Temperature	-	< 40°C
Soldering Temperature	-	260°C, 10 seconds within 5°C of actual peak temperature

## 7 DC Characteristics

\*  $T_A = -40^{\circ}\text{C} \sim +85^{\circ}\text{C}$ ,  $V_{DD} = 2.7\text{V} \sim 3.7\text{V}$  unless otherwise specified

Parameter	Symbol	Pin	Conditions	Value			Unit
				Min	Typ	Max	
Input Low Voltage	$V_{IL}$	EN, PWM	$V_{DD} = 2.7\text{V} \sim 3.7\text{V}$	-	-	0.4	V
Input high Voltage	$V_{IH}$	EN, PWM	$V_{DD} = 2.7\text{V} \sim 3.7\text{V}$	1.0	-	-	V
Quiescent Power Supply Current	$I_{DDQ}$	VDP, VDN	$V_{PWM} = 50\% \text{ Duty,}$ $R_L = 30\Omega$	8	13	17	mA
Output Offset Voltage	$V_{OS}$	VDP, VDN	$V_{PWM} = 50\% \text{ Duty,}$ $R_L = 30\Omega$	-55	25	55	mV
Output Current	$I_{OUT}$	VDP, VDN	$V_{OH}, V_{OL} \leq 200\text{mV}$	-	200	-	mA
Input Leakage Current	$I_{IL}$	All Pins	$V_{IN} = V_{IH} \text{ or } V_{IL}$ ( $V_{EN} = 0$ )	-	-	$\pm 1$	$\mu\text{A}$
Pin Capacitance	$C_{IO}$	All Pins	$V_{DDIO} = 3.7\text{V}$	-	10	-	pF

## 8 Package Dimension

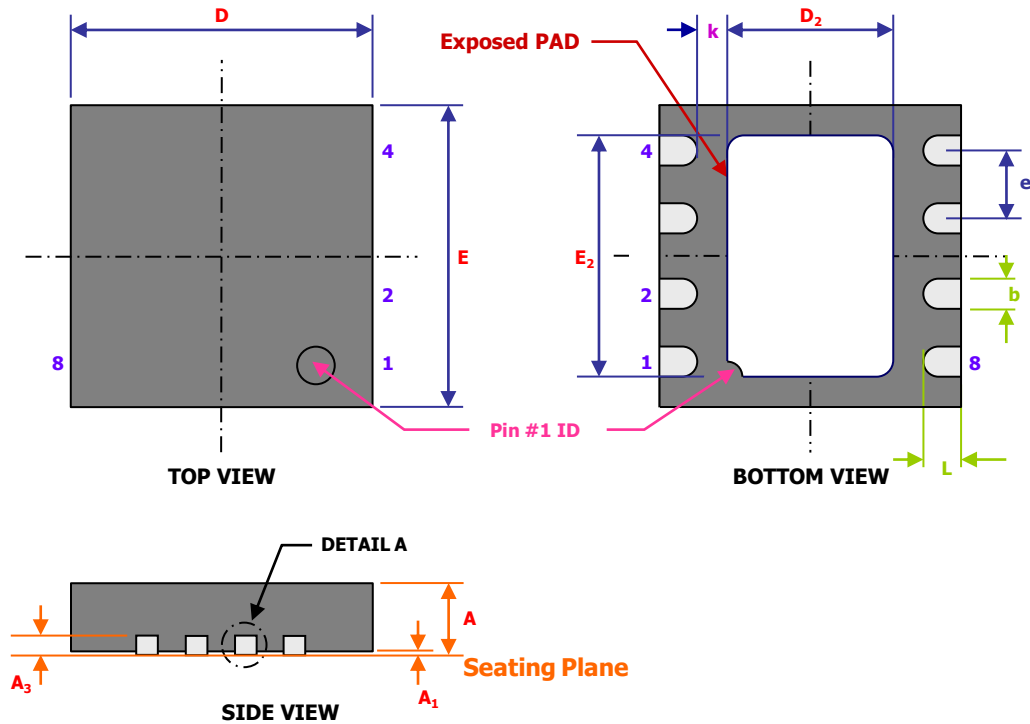

Symbol	Dimensions [mm]		
	Min.	Nom.	Max.
A	0.50	0.55	0.60
A <sub>1</sub>	0.00	0.01	0.05
A <sub>3</sub>	0.15 REF		
D	1.90	2.00	2.10
E	1.90	2.00	2.10
D <sub>2</sub>	0.80	0.90	1.00
E <sub>2</sub>	1.60	1.70	1.80
B	0.15	0.20	0.25
E	0.50 BSC		
L	0.25	0.30	0.35
k	-	0.25	-

Notes:

1. All dimension are in mm. Angles in Degrees.
2. Dimension b applies to Plated Terminal & is measured between 0.05 and 0.10mm from terminal tip. If the terminal has the optional radius on the other end of the terminal.

- The Dimension b should not be measured in that radius area.
3. Max. package warpage is 0.05mm.
  4. Max. allowable burrs is 0.076mm in all directions.
  5. Bilateral coplanarity zone applies to the exposed heat sink slug as well as the terminals.